

## Celiac disease, type 1 diabetes mellitus and autoimmune thyroid disorder: a case report

Dr. E. Schneider<sup>1</sup>, Dr. T. Braun<sup>1</sup>, Dr. L. Keller<sup>1</sup>, Dr. M. Vogel<sup>1\*</sup>

<sup>1</sup> Department of Clinical Medicine and Translational Research, University of Heidelberg, Heidelberg, Germany

### Abstract

In celiac disease, the intake of gluten causes malabsorption due to atrophy of the intestinal villi. Its clinical course depends on the compliance of a gluten free diet, which can be verified by serological markers. Celiac disease is associated to other autoimmune entities (type 1 diabetes mellitus, connective diseases, thyroid disease). This should be taken into account in the differential diagnosis of the clinical pictures of these patients. A case report believed to that illustrates the association of celiac disease and primary autoimmune thyroid disorder, whose symptoms were initially a consequence of non-compliance with a gluten free diet, is presented.

### Keywords:

*Erectile dysfunction,  
Hypertension,  
Endothelial dysfunction,  
Vasodilation,  
Penile blood flow,  
Libido.*

### Introduction

Patients with type 1 diabetes mellitus (T1D) are at a great risk for developing autoimmune diseases. It is well recognized that T1D can be associated with celiac disease (CD) and autoimmune thyroid disorders (ATD). Recent studies regarding CD and T1D have indicated that the frequency of this association can vary from 1.7% to 16% (Lughetti et al., 2003; Komer et al., 2002). The frequency of ATD in patients with T1D is reported to vary from 3.9% to 40% in different populations (Sumnik et al., 2003). On the other hand, the frequency of ATD in patients with CD varies from 4.1% to 14% (Hakanen et al., 2001). Growth, bone metabolism and fertility can be affected by these autoimmune associations (Hakanen et al., 2001).

The inflammatory disorders T1D and CD co-segregate in populations, suggesting a common genetic origin. Both are associated with the HLA class II genes on chromosome 6p21.

T1D and CD tend to co-exist due to similar underlying genetic predisposition. CD and T1D belong to the group of autoimmune illnesses, the pathogenesis of which involves the body's immune system destroying its own cells and tissues. In recent years, a dynamic increase of autoimmune illnesses morbidity has been observed, especially in the paediatric population. Autoimmune illnesses may affect almost all systems and organs of the body (Szalecki, 2009). CD is one of the most common autoimmune disease-based disorders; it is elicited by a failure of oral tolerance towards wheat, gluten and related cereals, which results in a multisystem inflammation of the intestinal tract. CD involves damage to the mucous membrane of the small intestine manifested by the atrophy of intestinal villi, crypt hyperplasia and intra-epithelial lymphocyte infiltration.

T1D is characterized by a deficit or absence of insulin resulting from T cell-mediated destruction of beta cells of the pancreas, which produce insulin (Atkinson and Maclaren, 1994; Woś and Grzybowska-Chlebowczyk, 2009). Children with T1D have an increased risk of developing other autoimmune disorders like Hashimoto's thyroiditis, Addison disease, vitiligo and celiac disease (Barker, 2006). The relation between T1D and these pathologies is a common genetic background. All of these diseases are associated with organ-specific autoantibodies that can be detected before the development of clinical diseases; consequently, patients affected by T1D usually undergo a scheduled (usually once a year) screening for these pathologies.

CD and T1 diabetes occur in genetically predisposed persons. Genetic predisposition for CD is mainly associated with class II HLA genes of histocompatibility complex on chromosome 6p21 (CELIAC 1). The majority of patients with CD have the HLA DQ2 antigen coded by alleles DQA1\*0501 and DQB1\*0201, and the rest of them have HLA DQ8 coded by alleles DQA1\*0301 and DQB1\*0302. Less than 1% of patients suffering from CD lack any of the HLA alleles associated with predisposition to the illness. However, HLA-associated genes that predispose to CD are found in as much as 30–40% of healthy people. Thus, their presence seems to be essential, but indecisive for the occurrence of CD. Other genes, not associated with HLA but involved in the pathogenesis of CD as well, include the

following: CELIAC 2 (5q31-33), CELIAC 3 (2q33) and CELIAC 4 (19p13.1) (Di Sabatino and Corazza, 2009). It usually develops in HLA-DQ2/8 positive individuals.

Class II HLA genes are also responsible for 40–50% of the genetic risk of T1D occurrence. The highest risk for the occurrence of T1D is genotype DR3-DQA1\*0501-DQB1\*0201/DR4-DQA1\*0301-DQB1\*0302, whereas – DR15-DQA1\*0102-DQB1\*0602 is associated with dominant protection (Silva et al., 2008).

The first association between T1D and CD was suggested in 1969 (Walker-Smith and Grigor, 1969). Antigen HLA DQ2 occurs in 80% of patients with T1D and CD, and 49% of patients with T1D without CD. This means that patients having antigen HLA DQ2 or HLA DQ8 are the most predisposed to the co-existence of CD and T1D (Sumnik et al., 2000).

The increased prevalence of CD in patients with T1D is due to an overlap in the genetic susceptibility to both diseases conferred by the HLADR3/DQ2 (Rewers and Eisenbarth, 2012). This haplotype is present in over 90% of patients with CD and 55% of those with T1D, compared with only 20%-25% of the general population of European ancestry. HLA-DQ8 also confers a risk of T1D (Rewers and Eisenbarth, 2012).

CD affects at least 10% of patients with T1D at some point in their lives (Rewers et al., 2004), with a prevalence that varies between 0.6%-16.4%, according to different studies (Marchese et al., 2013; Camarca et al., 2012; Lohi et al., 2007). The prevalence of CD among children with T1D is significantly higher than in non-diabetic children (in Western countries CD affects around 1%-2% of the non-diabetic population).

Less than 10% of patients with T1D who develop CD show gastrointestinal symptoms, while most of the children are either asymptomatic or only mildly symptomatic. Therefore, children affected by T1D undergo screening for CD. Usually, celiac autoantibodies are tested at the time of diabetes onset and yearly during follow-up, but debate exists about timing and frequency for screening (Freemark and Levitsky, 2003; Sud et al., 2010). When celiac antibodies are detected (ideally confirmed at least twice), it is mandatory to perform esophagogastroduodenoscopy with bowel biopsies to confirm diagnosis (Husby et al., 2012).

## **Presentation**

A 17-year-old male presented to the hospital with an 8 month history of difficulty walking and a possible cerebellar ataxia. Throughout the years prior to his presentation, his clinical history was the following:

At 7 years of age he was diagnosed with T1D. He started with insulin injections.

At 14 years of age he was diagnosed with a clinical diagnosis of celiac disease. The patient was started on a gluten-free diet, which resulted in less abdominal bloating.

One year later, endoscopy was performed and biopsy was taken. The examination of intestinal biopsy revealed CD. Villous atrophy with hyperplasia of the crypts and increased intraepithelial lymphocyte count was found on examination of biopsy. The diagnosis of celiac disease was based on the criteria of the European Society of Paediatric Gastroenterology, Hepatology and Nutrition (ESPGHAN) (Walker-Smith et al., 1990). Hypertrophic cardiomyopathy was diagnosed by Colour Doppler Echocardiography. Thyroid function test [serum free thyroxine (T4)] and autoimmune abnormalities [thyroid antithyroglobulin (TgAb) and antithyroperoxidase (TPOAb)] levels were in normal range.

At 17 years of age his physical examination revealed weight loss, hypogonadism and motor disorders (gait disorder). The patient was admitted for further investigations, his physical examination revealed a progressive gait disorder. On laboratory examination, complete blood count analysis was normal except A1c levels (8.5%). Erythrocyte sedimentation rate was normal. He had no evidence of iron deficiency anemia. Biochemical examinations of electrolyte were normal except magnesium 1.72 mg/dL (range 1.5-2.3 mg/dL) and phosphate 9.5 mg/dL (range 2.5-5.6 mg/dL). He showed serum folate and vitamin B12 levels deficiency. His thyroid function tests revealed a morning thyroid-stimulating hormone (TSH) level of 5.14 mU/mL (normal range: 0.6-4.0 mU/mL) and thyroxine (T4) level of 9.2 µg/dL (normal range: 5.5-11 µg/dL). The serologic markers for celiac disease were negative [tissue transglutaminase immunoglobulin (Ig) A and G, anti-gliadin Ig A and G, anti endomysium Ig A]. The serologic markers for autoimmune abnormalities of thyroid gland [thyroid antithyroglobulin (TgAb) and antithyroperoxidase (TPOAb)] levels were in normal range. Nuclear magnetic resonance spectroscopy of the brain demonstrated bilateral

occipital lesions. The patient was started on immunoglobulin anti-GAD (glutamic acid decarboxylase antibodies), corticosteroid short term, and folic acid.

Later control showed: normal blood count analysis, normal electrolytes values, normal levels of TSH and T4, negative transglutaminase immunoglobulin (Ig) A, elevated levels of antithyroperoxidase (TPOAb): 253.4 IU (normal range < 60 IU/ml) and thyroid antithyroglobulin (TgAb): 91.3 IU (normal range < 60 IU/ml). During a clinic visit, he admitted non-compliance with a gluten free diet. His physical examination revealed a progressive gait disorder with bilateral ataxia of the four limbs and mild pubertal delay.

At the time of this report, he has normal blood count analysis and normal electrolytes values. Our patient is still receiving folic acid, enalapril, azatoprine, Insulin glargine, Insulin aspartic therapy for correction. The patient continues with a gluten-free diet and short term of treatment with immunoglobulin's (three days).

Family history was positive for CD (mother), T1D (paternal great-grandmother) and CD and T1D (sister). His sister of 14 years old was diagnosed with T1DM at 6 years and CD at 8 years old. Moreover, she has cerebellar ataxia associated with gluten intolerance and autoimmune epilepsy and short stature (Figure 1).

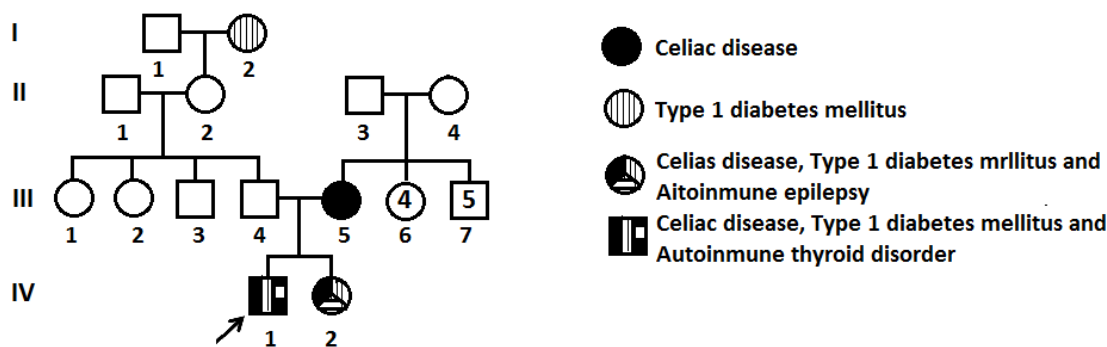

Figure 1: Pedigree of the family. The mother, CD and the father has normal phenotype and the sister has CD and T1D. Only these family members were tested.

## Discussion

Type 1 diabetes (T1D) is one of the most common chronic childhood diseases. Although T1D mainly results from T-lymphocyte mediated destruction of insulin producing beta cells within pancreatic islets, appearance of islet autoantibodies (I Abs) in the peripheral blood is currently the most reliable marker to detect the autoimmune process leading to clinical T1D (Atkinson et al., 2014). Autoantibodies directed against insulin (IAA), glutamic acid decarboxylase (GAD), insulinoma antigen 2 (IA-2A), and zinc transporter-8 (ZnT8A) are routinely measured. The incidence of T1D is increasing worldwide at 3–5% each year and has doubled in the last two decades, especially in young children (Harjutsalo et al., 2008; Vehik et al., 2007). I Abs usually appear years before overt clinical disease and nearly all children with the presence of  $\geq 2$  I Abs develop clinical T1D when followed over time (Ziegler et al., 2013). The clinical classification of T1D has recently been re-defined to begin with the presence of  $\geq 2$  I Abs (Insel et al., 2015). Children at risk for T1D need to be identified prior to symptom onset to 1) prevent life-threatening diabetic ketoacidosis, 2) define individuals at high risk for intervention studies, and 3) identify environmental triggers for the onset of islet autoimmunity. Up to 40% of T1D patients develop an additional autoimmune disorder, and one in four children at risk for T1D in the Diabetes Autoimmunity Study in the Young (DAISY) develop islet, celiac, thyroid or rheumatoid autoimmunity (Barker et al., 2005; Triolo et al., 2011; de Graaff et al., 2007). Unfortunately, there is no easy and inexpensive tool to screen for these conditions. In a large effort, all DAISY and TEDDY (The Environmental Determinant of Diabetes in the Young) study participants are screened for autoantibodies to tissue transglutaminase (TGA) for celiac disease autoimmunity. Persistent TGA positivity and celiac disease are secondary endpoints in both studies (Norris et al., 2005; Liu et al., 2014), and the TEDDY study has recently initiated screening for autoimmune thyroid disease including antibodies directed against thyroid peroxidase (TPOA) and thyroglobulin (ThGA) in subset of samples. People with positive TPOA and/or ThGA are at risk for developing autoimmune thyroid disease. All of these autoimmune diseases, including T1D, often begin in childhood.

Autoimmune disorders such as ATD and CD are relatively common in diabetic children and serological screening studies evaluating the prevalence of CD in patients with T1D have gained momentum in recent years. **Rozsai et al. (2002)** reported anti endomysium Ig A (EMA) positivity of 6.6% in 196 T1D patients. Among these, 1.5% was symptomatic CD cases. The highest association rate (16.4%) was reported by **Barera et al. (2002)**. These authors used antigliadin antibody and EMA tests as screening methods (**Collin et al., 2002**). **Cherubini et al. (2002)** reported EMA positivity in 180 cases with T1D and their 116 healthy male siblings as 6.6% and 5.2%, respectively, emphasizing the need for serological screening for CD in siblings of T1D patients.

Investigations have been focused on the effect of administering a gluten-free diet based on a diagnosis of CD on the metabolic control of diabetes (**Thain et al., 1974**). A diet initiated upon determination of CD in a child with T1D and suffering from malnutrition is expected to lead to weight gain and reduction in the number of hypoglycemic episodes. A decrease in hypoglycemic attacks in pediatric cases with T1D associated with CD after starting a gluten-free diet had been observed by several investigators (**Collin et al., 2002**). However, there are also studies reporting no change in the incidence of hypoglycemia and ketoacidosis by gluten-free diet in children with T1D (**Sumnik et al., 2002**).

It has been reported that the CD-related antibodies increase in frequency in the first-degree relatives of T1D patients (**Souknonen et al., 2001**). Studies have clearly shown that there is a significantly higher incidence of HLA B8, DR3 and DQW2 in CD. The common genetic background may play a role in the immune response mechanism (**Lughetti et al., 2003**). Recent studies have shown that HLADQ polymorphisms (HLA-DQA1 DQB1) significantly modify the risk of ATD in children with T1D (**Sumnik et al., 2003**).

Although the underlying mechanisms with respect to the development of multiple autoimmune diseases within the same person are largely unknown, recent progress including the identification of several loci with associations to more than one autoimmune disease (**Wellcome Trust Case Control Consortium, 2007**) suggests that common genetic factors or immunological processes are present among the different autoimmune diseases. As the most common coexisting organ specific autoimmune disease associated with T1D is autoimmune thyroid disease, children with T1D, or with a family history of T1D, should be aware of the tendency to develop additional autoimmune disorders, especially autoimmune thyroid disease.

## **Conclusion**

T1D and CD are autoimmune diseases with considerable clinical and pathogenic overlap. While HLA is a clear common risk factor, additional genetic and environmental factors likely play important roles in disease initiation. Given increased prevalence of having both conditions and frequent lack of classic intestinal symptoms, CD screening is currently recommended. Sensitive and specific serology tests are available, and when positive, should be confirmed by upper endoscopic biopsies showing villous changes and increased intraepithelial lymphocytes. A GFD may be challenging for some patients who already have dietary restrictions; however, it appears as if this diet may provide overall benefit (or at least no harm) in T1D patients though the data in this area is variable. Emerging evidence underscores the pathogenic overlap between these two conditions. While HLA susceptibility has been known as a common risk factor, GWAS have identified a number of non-HLA genetic risk variants. Environmental factors including introduction of solids, breast-feeding, viral infections and notably the gut microbiome appear to contribute to risk of developing both diseases individually. Additional studies are needed to elucidate how these factors predispose some individuals to getting both conditions.

## **References**

1. **Lughetti L**, Bulgarelli S, Forese S. Endocrine aspects of coeliac disease. *JPEM*. 2003; 16:805–818.
2. **Komer A**, Arato A, Madaasy L, Rideg O. Increased risk of other autoimmune disorders in **children with type I diabetes mellitus**. *JPEM*. 2002; 15:1064.
3. **Sumnik Z**, Drevinek P, Snajderova M, Kolouskova S, Sedláková P, Pechova M, Vavrínek J, Cínek O. HLA-DQ Polymorphism Modify the Risk of Thyroid Autoimmunity in children with Type 1 Diabetes Mellitus. *JPEM*. 2003; 16:851–858.
4. **Hakanen M**, Luotola K, Salmi J, Laippala P, Kaukinen K, Collin P. Clinical and subclinical autoimmune thyroid disease in adult celiac disease. *Dig Dis Sci*. 2001; 46:2631–2635.
5. **Szalecki M**. Diabetes mellitus and other autoimmunological diseases. *Przegl Ped*. 2009; 39:260–5.

6. **Woś H, Grzybowska-Chlebowczyk U.** Coexistence of coeliac disease and diabetes type 1 in children. *Ped Współcz.* 2009; 11:99–101.
7. **Di Sabatino A, Corazza GR.** Coeliac disease. *Lancet.* 2009; 373:1480–93.
8. **Silva ME, Mory D, Davini E.** Genetic and humoral autoimmunity markers of type 1 diabetes: from theory to practice. *Arq Bras Endocrinol Metabol.* 2008; 52:166–80.
9. **Sumnik Z, Kolousková S, Cinek O, Kotalová R, Vavrinec J, Snajderová M.** HLA-DQ\*05-DQB1\*0201 positivity predisposes to coeliac disease in Czech diabetic children. *Acta Paediatr.* 2000;89:1426–30.
10. **Di Sabatino A, Corazza GR.** Coeliac disease. *Lancet.* 2009; 373:1480–93.
11. **Atkinson MA, Maclaren NK.** The pathogenesis of insulin-dependent diabetes mellitus. *N Engl J Med* 1994; 331: 1428-1436.
12. **Barker JM.** Clinical review: Type 1 diabetes-associated autoimmunity: natural history, genetic associations, and screening. *J Clin Endocrinol Metab* 2006; 91: 1210-1217.
13. **Walker-Smith JA, Grigor W.** Coeliac disease in a diabetic child. *Lancet* 1969; 1: 1021.
14. **Rewers M, Eisenbarth GS.** Autoimmunity: Celiac disease in T1DM-the need to look long term. *Nat Rev Endocrinol* 2012; 8: 7-8.
15. **Rewers M, Liu E, Simmons J, Redondo MJ, Hoffenberg EJ.** Celiac disease associated with type 1 diabetes mellitus. *Endocrinol Metab Clin North Am* 2004; 33: 197-214.
16. **Marchese A, Lovati E, Biagi F, Corazza GR.** Coeliac disease and type 1 diabetes mellitus: epidemiology, clinical implications and effects of gluten-free diet. *Endocrine* 2013; 43: 1-2.
17. **Camarca ME, Mozzillo E, Nugnes R, Zito E, Falco M, Fattorusso V, Mobilia S, Buono P, Valerio G, Troncone R, Franzese A.** Celiac disease in type 1 diabetes mellitus. *Ital J Pediatr* 2012; 38: 10.
18. **Lohi S, Mustalahti K, Kaukinen K, Laurila K, Collin P, Rissanen H, Lohi O, Bravi E, Gasparin M, Reunanen A, Mäki M.** Increasing prevalence of coeliac disease over time. *Aliment Pharmacol Ther* 2007; 26: 1217-1225.
19. **Freemark M, Levitsky LL.** Screening for celiac disease in children with type 1 diabetes: two views of the controversy. *Diabetes Care* 2003; 26: 1932-1939.
20. **Sud S, Marcon M, Assor E, Palmert MR, Daneman D, Mahmud FH.** Celiac disease and pediatric type 1 diabetes: diagnostic and treatment dilemmas. *Int J Pediatr Endocrinol* 2010; 2010: 161285.
21. **Husby S, Koletzko S, Korponay-Szabó IR, Mearin ML, Phillips A, Shamir R, Troncone R, Giersiepen K, Branski D, Catassi C, Lelgeman M, Mäki M, Ribes-Koninckx C, Ventura A, Zimmer KP.** European Society for Pediatric Gastroenterology, Hepatology, and Nutrition guidelines for the diagnosis of coeliac disease. *J Pediatr Gastroenterol Nutr* 2012; 54: 136-160.
22. **Atkinson MA, Eisenbarth GS, Michels AW.** Type 1 diabetes. *Lancet* 2014;383:69–82.
23. **Harjutsalo V, Sjoberg L, Tuomilehto J.** Time trends in the incidence of type 1 diabetes in Finnish children: a cohort study. *Lancet* 2008;371:1777–82.
24. **Vehik K, Hamman RF, Lezotte D, Norris JM, Klingensmith G, Bloch C, Rewers M, Dabelea D.** Increasing incidence of type 1 diabetes in 0- to 17-year-old Colorado youth. *Diabetes Care* 2007; 30:503–9.
25. **Ziegler AG, Rewers M, Simell O, Simell T, Lempainen J, Steck A, Winkler C, Ilonen J, Veijola R, Knip M, Bonifacio E, Eisenbarth GS.** Seroconversion to multiple islet autoantibodies and risk of progression to diabetes in children. *JAMA* 2013;309:2473–9.
26. **Insel RA, Dunne JL, Atkinson MA, Chiang JL, Dabelea D, Gottlieb PA, Greenbaum CJ, Herold KC, Krischer JP, Lernmark Å, Ratner RE, Rewers MJ, Schatz DA, Skyler JS, Sosenko JM, Ziegler AG.** Staging presymptomatic type 1 diabetes: a scientific statement of JDRF, the Endocrine Society, and the American Diabetes Association. *Diabetes Care* 2015;38:1964–74.
27. **Barker JM, Yu J, Yu L, Wang J, Miao D, Bao F, Hoffenberg E, Nelson JC, Gottlieb PA, Rewers M, Eisenbarth GS.** Autoantibody "subspecificity" in type 1 diabetes: risk for organ-specific autoimmunity clusters in distinct groups. *Diabetes Care* 2005;28: 850–5.
28. **Triolo TM, Armstrong TK, McFann K, Yu L, Rewers MJ, Klingensmith GJ, Eisenbarth GS, Barker JM.** Additional autoimmune disease found in 33% of patients at type 1 diabetes onset. *Diabetes Care* 2011; 34:1211–3.
29. **de Graaff LC, Smit JW, Radder JK.** Prevalence and clinical significance of organspecific autoantibodies in type 1 diabetes mellitus. *Neth J Med* 2007;65:235–47.
30. **Norris JM, Barriga K, Hoffenberg EJ, Taki I, Miao D, Haas JE, Emery LM, Sokol RJ, Erlich HA, Eisenbarth GS, Rewers M.** Risk of celiac disease autoimmunity and timing of gluten introduction in the diet of infants at increased risk of disease. *JAMA* 2005;293:2343–51.

31. **Liu E**, Lee HS, Aronsson CA, Hagopian WA, Koletzko S, Rewers MJ, Eisenbarth GS, Bingley PJ, Bonifacio E, Simell V, Agardh D; TEDDY Study Group. Risk of pediatric celiac disease according to HLA haplotype and country. *N Engl J Med* 2014; 371:42–9.
32. **Walker-Smith JA**, Guandalini S, Schmitz J, Shmerling DH, Visakorpi JK. Revised criteria for diagnosis of coeliac disease. Report to working group of European Society of Paediatric Gastroenterology and Nutrition. *Arch Dis Child*. 1990; 65: 909-911.
33. **Rozsai B**, Kozari A, Hermann R, Soltesz G. Associated autoimmunity in Type I Diabetes. *JPEM*. 2002;15:1067.
34. **Barera G**, Bonfanti R, Viscardi M. Occurrence of CD after onset of type I diabetes: a 6 year prospective longitudinal study. *Pediatrics*. 2002;109:833–838.
35. **Collin P**, Kaukinen K, Valimaki M, Salmi J. Endocrinological Disorders and Celiac Disease. *Endocrine Reviews*. 2002;23:464–483.
36. **Cherubini V**, Fabiani PE, Scalari PA. High prevalence of Celiac Disease in siblings of Type 1 Diabetic Children. *JPEM*. 2002;15:1075.
37. **Thain ME**, Hamilton JR, Erlich RM. Co-existence of diabetes mellitus and celiac disease. *J Pediatr*. 1974;85:527–529.
38. **Sumnik Z**, Schober E, Waldhor T. Coeliac disease in children and adolescents with type I diabetes mellitus– a multicenter case control study. *JPEM*. 2002;15:1089.
39. **Wellcome Trust Case Control Consortium**. Genome-wide association study of 14,000 cases of seven common diseases and 3,000 shared controls. *Nature* 2007;447: 661–78.
40. **Soukonnen T**, Itonen J, Akerblom HK, Savilahti E. Prevalence of celiac disease in siblings of patients with type I diabetes is related to the prevalence of DQB1\*02 allele. *Diabetologia*. 2001;44:1051–1053.
41. **Lughetti L**, Bulgarelli S, Forese S. Endocrine aspects of coeliac disease. *JPEM*. 2003; 16:805–818.
42. **Sumnik Z**, Drevinek P, Snajderova M, Kolouskova S, Sedláková P, Pechova M, Vavrínek J, Cínek O. HLA-DQ Polymorphism Modify the Risk of Thyroid Autoimmunity in children with Type 1 Diabetes Mellitus. *JPEM*. 2003;16:851–858.