

Development of a wearable smart frame for monitoring and displaying biomedical signals

Dr. S. Ahmed¹, Dr. N. Khan¹, Dr. F. Rahman¹, Dr. M. Ali^{1*}

¹ Department of Medicine and Clinical Research, Aga Khan University, Karachi, Pakistan

ABSTRACT

This article presents the design of a voltmeter using Arduino and displays the value on a smart glass via Bluetooth technology. Actually the project is based on safety prospective of workers who are working on a high voltage system, the system is designed in such a way that a worker can get information about the condition of the instrument, that he/she is handling through the smart glass with the help of Bluetooth technology. Here Arduino is used as voltmeter, store the analog data and transmit via Bluetooth device to the smart glass where another Bluetooth module is also implemented to collect the data. When we display data on the screen of a smart glass, we use lights telescopic property of reflection. The process will reduce the risk factor associated with high voltage system. Also the application of this system is user friendly which gives comfort to the workers working in the industries where high voltage instruments are being used. In today's era the technology upgrades rapidly, so it becomes necessary to improve the safety prospective. This project will only give us an idea to initialize the smart technology in the field of safety in engineering/Technology.

Keywords: Arduino, bluetooth module (HC-05), smart glass, voltmeter

INTRODUCTION

In this project we are trying to build a system which will protect the life of workers, who work on a high voltage system. The idea is simple. Here we have designed the system using arduino which measures the voltage condition of the system and through a Bluetooth Module it will transfer the value to another one which is connected to a smart glass's OLED display. The data is available on the display which is reflected on the plane mirror (here we use light's reflection property, which is used in telescope) and the reflected data will be displayed on the glass of a worker. The glass can be used as specs to save the workers from high voltage in the work area.

AIM OF THE PROJECT

High electricity is a dangerous to handle. The people, who are associated with such profession, they have to deal with the risk of the high voltage instruments and high

voltage line. So we have tried to build a tool or device which can reduce some amount of risk for the workers, dealing with high voltage components. This glass can save the life of worker. Consumption of time is less while we use this concept.

FEATURES OF THE SYSTEM

- 1) Low cost Device.
- 2) Monitoring can be done from a distance.
- 3) Portable.
- 4) Safe to use.

COMPONENTS

- 1) Arduino
- 2) Bluetooth Module (HC-05)
- 3) OLED Display
- 4) Plane Mirror
- 5) Convex Lens
- 6) Glass/Frame

DESIGN PROCEDURE

First we have to measure the value of voltage through voltmeter which is made by Arduino. Then we have to

transmit this value through a Bluetooth module HC-05 to another Bluetooth module connected to a smart glass

display system. Here we use light's reflection property to show the display on the glasses of the specs.

BLOCK DIAGRAM

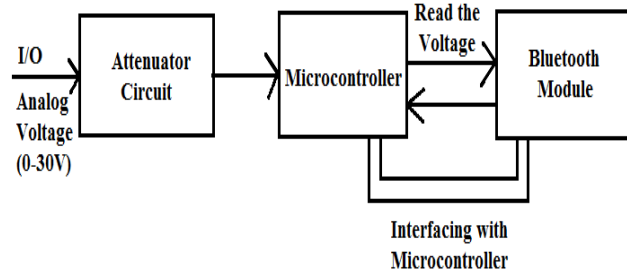

Fig.1: Block Diagram of the Sender Portion.

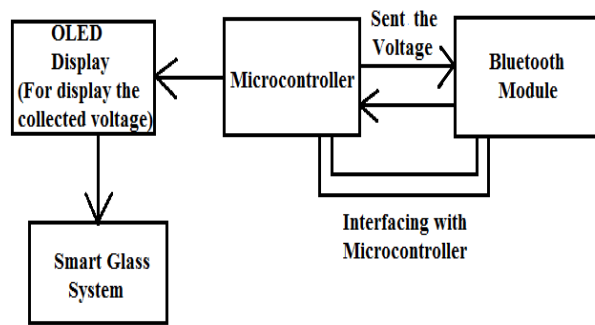

Fig.2: Block Diagram of the Receiver Portion.

CONCEPT OF CONVEX LENS

Convex lenses are thicker at the middle. Rays of light that pass through the lens are brought closer together (they converge). A convex lens is a **converging lens**.

convex lens the refracted rays converge at one point called the

Principal Focus

The distance between the principal focus and the centre of the lens is called the **focal length**.

When parallel rays of light pass through a

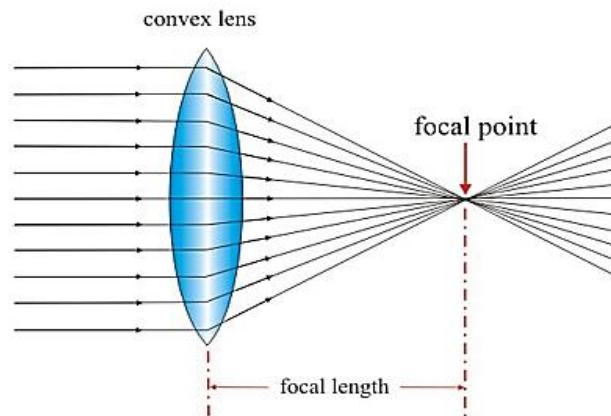

Fig. 3: Convex Lens.

CONCEPT OF REFLECTION IN PLANE MIRROR

The reflection of light from a plane mirror can be summarized by the following laws:

1. The angle of incidence (i) is equal to the angle of reflection (r)
2. The incident ray, reflected ray and the normal to the surface at the point of incidence all lie in the same plane.

The reflection from a plane (flat) mirror is shown in Figure 4. Note the normal line and the use of shading to represent the back of the mirror.

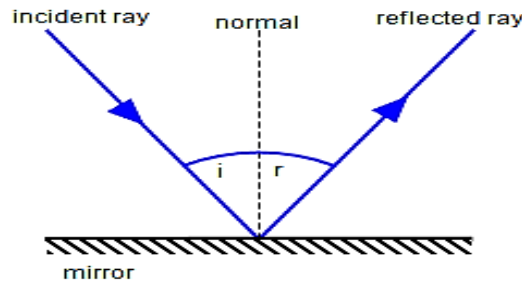

Fig.4: Reflection in Plane Mirror.

WORKING PROCEDURE

First of all we make the voltmeter using microcontroller (Arduino). In this voltmeter circuit we use attenuator circuit to calculate the voltage from 0 to 30 V. After collecting the voltage arduino sends the value from one Bluetooth module to another. Here we use two Bluetooth modules (HC-05), one is for sending the data and another one is for receiving the data. After that, in the receiving part

another Bluetooth module gets the voltage value and displays it on OLED display with the help of microcontroller (Arduino). Using reflection methodology, we display the voltage value on the glass/frame of a worker.

This smart glass system is designed by using convex lens, a plane mirror and a transparent glass reflector (use to display the value in front of the glass/frame of the worker).

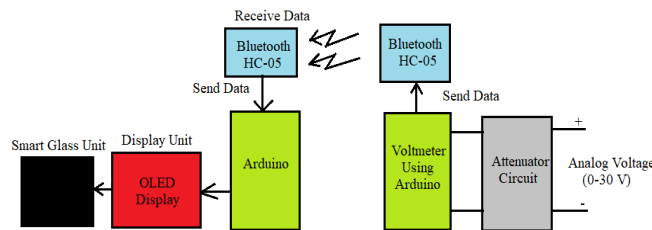

Fig. 5: Diagram of Full System.

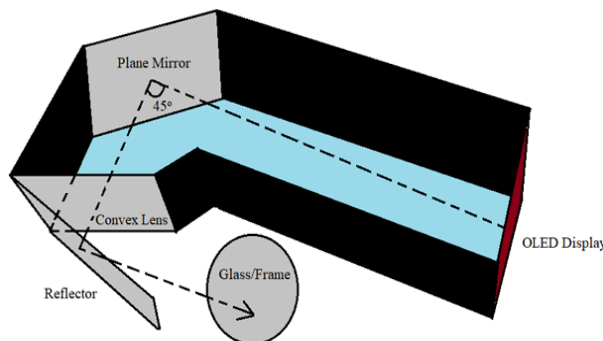

Fig.6: Smart Glass Working Diagram.

As per the digram of Figure 6, we place the plane mirror at an angle of 45° . So when the output of OLED display travels

through the black tunnel as a light particle, it is projected on the plane mirror and reflected to the convex lens, which is

placed in front of light's travelling path. As per the property of convex lens, the output of the convex lens meet at a particular point. This point is projected on the reflector, which is placed in front of the convex lens at a particular distance (focal point). Now this reflector, again reflects back the light particle (data) to the glass/frame of the worker. So the worker can see the output easily in front of his glass/frame.

DISCUSSION

In this paper we have tried to figure out the working methodology of the system. The usage of this device will help to reduce fetal injuries and save lives of workers. The technology is smart and portable. The cost is also low and is one of the safest devices.

FUTURE SCOPE

1. This system is designed for showing the values of analog voltage. In future we can modify it as an ammeter also. So we can measure both voltage-current and display it in the smart glass.

2. As this is a measuring glass display, so in future we can modify it to display different types of mathematical calculation, distance measurement, height measurement, depth measurement etc.
3. We can modify it as a mini projector which will display the data on a projector by pressing a single button, present on the glass/frame.

ACKNOWLEDGEMENTS

The authors would take this opportunity to express their profound gratitude and deep regards to Dream Institute of Technology, Kolkata 700075

REFERENCES

1. http://www.schoolphysics.co.uk/age16-19/Optics/Reflection/text/Reflection_index.html
2. <http://www.passmyexams.co.uk/GCE/physics/concave-lenses-convex-lenses.html>
3. https://www.researchgate.net/publication/315689420_Design_and_Evaluation_of_a_Smart-Glasses-based_Service_Support_System
4. <http://www.philippauschnabel.com/academic-research/fashionology-augmented-reality-smart-glasses/>